



# Village of Lombard

Building Division / Community Development Department  
255 E. Wilson Avenue, Lombard, IL 60148  
Tel: 630-620-5750 Fax: 630-629-2374

## Residential Water Heater Requirements

**Inspections Requirements: A final inspection is required after the installation of the water heater.**

1. All piping shall be properly supported.
2. All gas piping shall be solid, with no flexible connectors, schedule 40 Black Iron.
3. The gas valve shall be easily accessible and have a union and drip leg.
4. All flue pipe and fittings shall have 3 screws per joint. Draft hood shall be screwed down to the heater.
5. A full port  $\frac{1}{4}$ in valve shall be located on the cold side, with no valve on hot side.
6. Unions are required to be on hot and cold water lines. If dissimilar metal piping is used, di-electric unions shall be used.
7. Relief valve discharge pipes must be metallic, discharge within 6 inches of the floor and directed to a suitable drain in the same room.
8. No flexible connections shall be allowed on water lines.
9. Water Heater installations shall met the current Illinois State Plumbing code, International Mechanical Code, and follow manufacturer specifications.
10. All heaters not installed directly on concrete floor shall have a drain pan installed. Piped to an approved fixture.

**NOTE: TPR and Pan to be piped separate.**

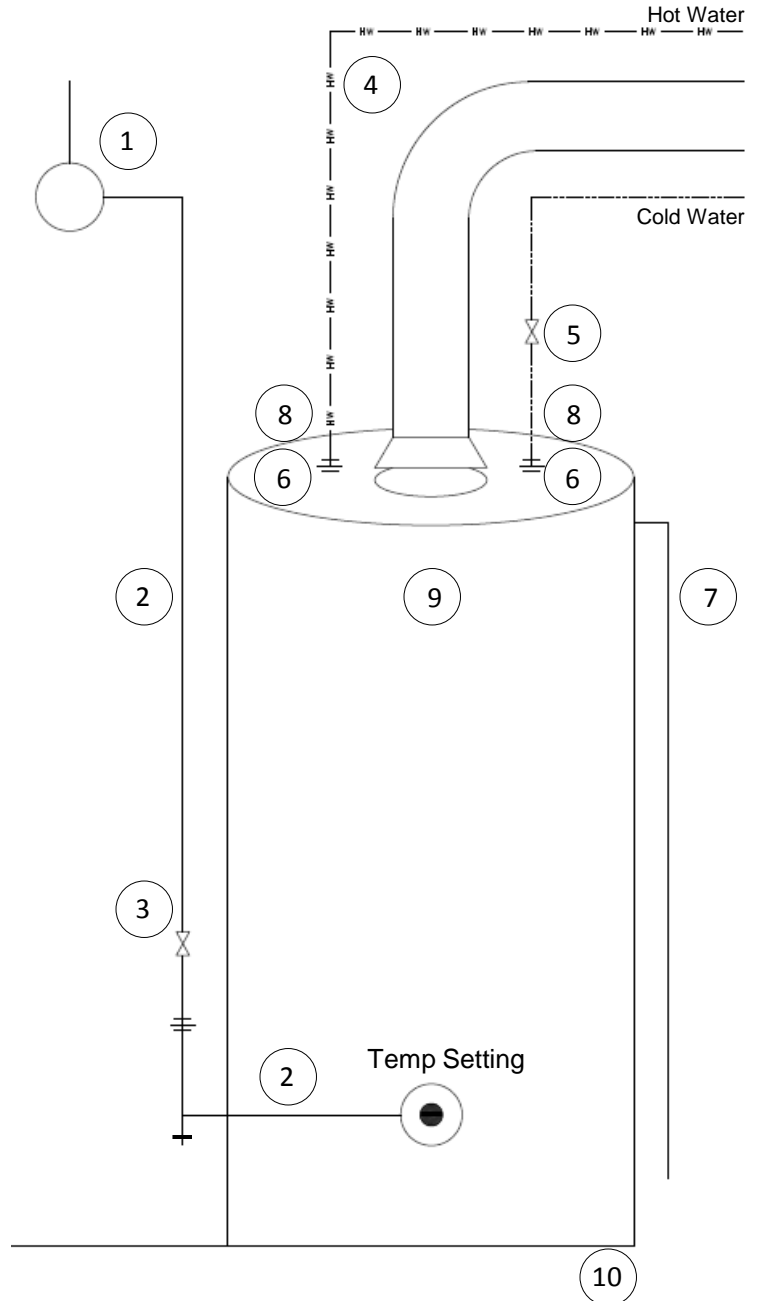

If you have any questions, or to schedule an inspections, please contact the Building Division at 630-620-5750 or email [buildingdivision@villageoflombard.org](mailto:buildingdivision@villageoflombard.org)